

uni Flex Plastic Chain

Series **uni 1703** Type -

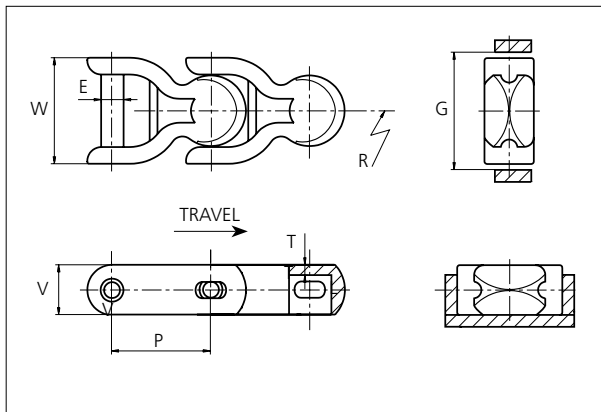

uni Flex Plastic Chain
 Side flexing chain
 Pitch: 50.0 mm (1.97 in)
 Backflex radius: 75.0 mm (3.00 in)
 Permissible tensile strength:
 POM material 4000 N (899 lbf)
 AR material 2800 N (630 lbf)
 Delivery: 6.1 m (20.0 ft)
 No. of links/box: 122

STANDARD

E		G		P		T		V	
mm	in	mm	in	mm	in	mm	in	mm	in
8.0	0.31	56.9	2.24	50.0	1.97	4.0	0.16	25.0	0.98

All dimensions are for chains in POM material.

Width (W)		Material & color	Pin material	Weight		Min. radius (R)	
mm	in			kg/m	lb/ft	mm	in
53.3	2.10	POM-D W AR W	SS304	1.4	0.94	150.0	5.91

Non standard material and color: See uni Material and Color Overview.
 Non standard pin material: See uni Material and Color Overview.

SIDE FLEXING

PITCH 50.0 MM/1.97 IN

Any questions? Please contact us.

Sprocket

No of teeth	Pitch diameter		Overall-diameter		Min. ø bore		Max. ø bore		Hub-diameter		A-dimension		B-dimension		Molded PA66 LG	Molded Cast Iron	Machined PA66	Machined SS304
	mm	in	mm	in	mm	in	mm	in	mm	in	mm	in	mm	in	Molded	Molded	Machined	Machined
Z8	130.7	5.14	133.0	5.20	20.00	0.80	40.00	1.60	63.00	2.50	47.90	1.90	82.40	3.20	x	x	x	x
Z10	161.8	6.37	166.1	6.50	20.00	0.80	40.00	1.60	63.00	2.50	64.50	2.50	97.30	3.80	x	x	x	x
Z12	193.2	7.61	196.0	7.70	20.00	0.80	40.00	1.60	63.00	2.50	80.80	3.20	112.40	4.40	x	x	x	
Z13	208.9	8.22	214.0	8.40	20.00	0.80	40.00	1.60	63.00	2.50	88.90	3.50	120.10	4.70	x	x	x	

Non standard material and color:
See uni Material and Color Overview.

Molded sprocket



Cast iron sprocket



Machined sprocket

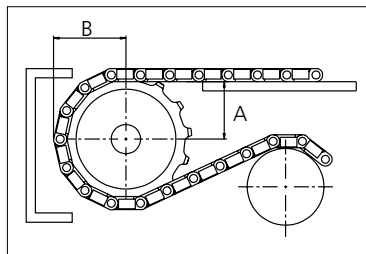

Please ensure that sufficient size shaft and keyway are chosen for corresponding load.

Other sprocket sizes are available upon request

Width of tooth: 15.8 mm/0.62 in

Width of sprocket: 42.3 mm/1.67 in

uni Retainer Rings: See uni Retainer Ring data sheet

uni Idler: See uni Idler data sheet

Any questions? Please contact us.

Morskate Aandrijvingen BV

Oosterveldsingel 47A
7558 PJ Hengelo (Ov)
The Netherlands

NL

T +31 (0)74 - 760 11 11
info@morskateaanrijvingen.nl
www.morskateaanrijvingen.nl

DE

T +49 692 - 222 34 95
info@morskateantriebstechnik.de
www.morskateantriebstechnik.de

EN

T +31 (0)74 - 760 11 11
info@morskatedrivetechnology.com
www.morskatedrivetechnology.com